

## General

Double diaphragm metering pumps of the Memdos GMR series can be supplied as single or duplex metering pumps. The pumps are used to meter large quantities at relatively low back pressures. They are frequently used in waste-water treatment to meter pH-regulating chemicals or flocculents. The metering pumps are available in three sizes as single metering pumps for 2000 to 4000 l/h. Different metering heads can be connected to the duplex metering pumps. The metering heads are then operating in a reciprocating mode and the quantity metered is set for both heads at the same time.

## Designs

Standard designs are: Single metering pump with left-hand metering head arrangement.

Type designation GMR Symbol 

Duplex metering pumps with two metering heads.

Type designation ZGMR Symbol 

## Metering head

The characteristic feature is the duplex diaphragm (7+8). The eccentric (5) guides the diaphragm (7) almost following the sine wave over the constant stroke. Since the large supporting disks always carry the whole surface of the diaphragm (7) in the maximum eccentric positions, a piston-like displacement effect is achieved. This results in a very high metering accuracy for diaphragm metering pumps independent of the back pressure. The front supporting disk for the suction stroke must not get into touch with the medium because of chemical resistance and the possible abrasivity. Therefore, a second diaphragm (8) is provided, which has a merely separating function and is therefore neutral in respect to forces. The medium side of the EPDM separating diaphragm (8) is coated with PTFE. A precisely dimensioned glycerin filling (6) acts as hydraulic push rod and thus the distance between the two diaphragms remains constant. Also the rear diaphragm chamber is partly filled with glycerin for lubrication purposes. The suction (12) and discharge valves (13) are spring-loaded flat seat valves. The suction (11) and discharge connections (10) are available in plastic or stainless steel design.



## Drive

There are two possibilities to drive the eccentric (5):

1. By means of a variable speed belt drive (3) with three-phase motor (2). The control range is approx. 1:6. The drive may only be adjusted while *the motor is rotating* (2).
2. By means of a three phase AC motor (2). The speed of this motor can be controlled within a range of 1:10 via also available frequency inverters.

## Legend

- 1 Handwheel for speed adjustment
- 2 three-phase AC motor
- 3 Belt gearbox
- 5 Eccentric
- 6 Glycerin filling
- 7 Rear diaphragm
- 8 Front diaphragm
- 9 Metering head
- 10 Discharge connection
- 11 Suction connection
- 12 Suction valve
- 13 Discharge valve

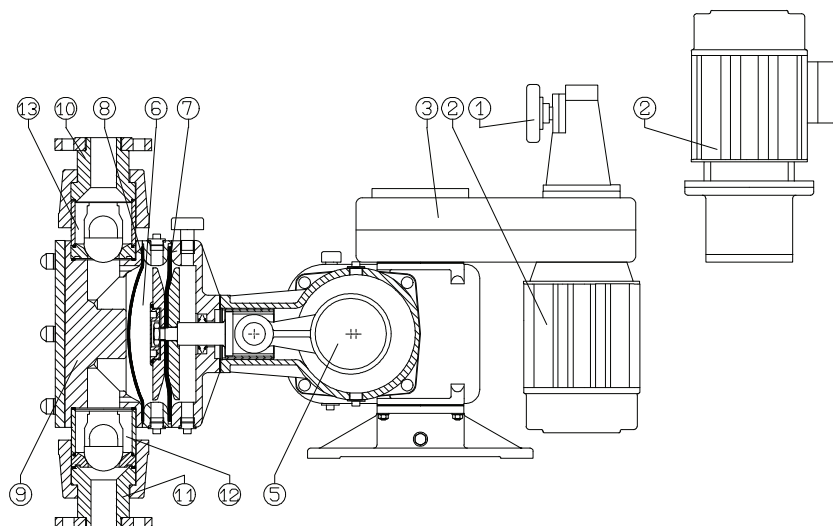

**Additional components**

Upon request, the Memdos GMR can be equipped with an inductive probe which samples the crankshaft to count the strokes. For diaphragm rupture detection, the front glycerin chamber can be monitored by means of a conductivity probe.

**Technical Data**

Memdos GMR			2000	3000	4000
Max. pressure		bar	4	3	2
Stepless control drive	Delivery rate	l/h	460 – 2300	500 – 3000	650 – 4000
	Stroke frequency	min <sup>-1</sup>	11 – 55	11 – 66	11 – 68
	Stroke volume	ml/stroke	680	750	980
Three phase motor drive at 2850 min <sup>-1</sup>	Delivery rate	l/h	2400	2600	3450
	Stroke frequency	min <sup>-1</sup>	58		
	Stroke volume	ml/stroke	680	750	980
Engine power		kW	2,2		
Diaphragm diameter		mm	280	330	
Stroke length		mm	23	26	32
Suction lift		mbar	120		
Max. supply pressure(Σ static and dynamic)		mbar	500		
Max. ambient temperature		°C	40		
Max. temperature of the medium		°C	40		
Weight	Plastic dosing head	kg	145	162	
	Stainless steel dosing head	kg	155	205	

For higher or lower capacities, three-phase a. c. motors can be connected to frequency inverters (refer to MB 4 70 01).

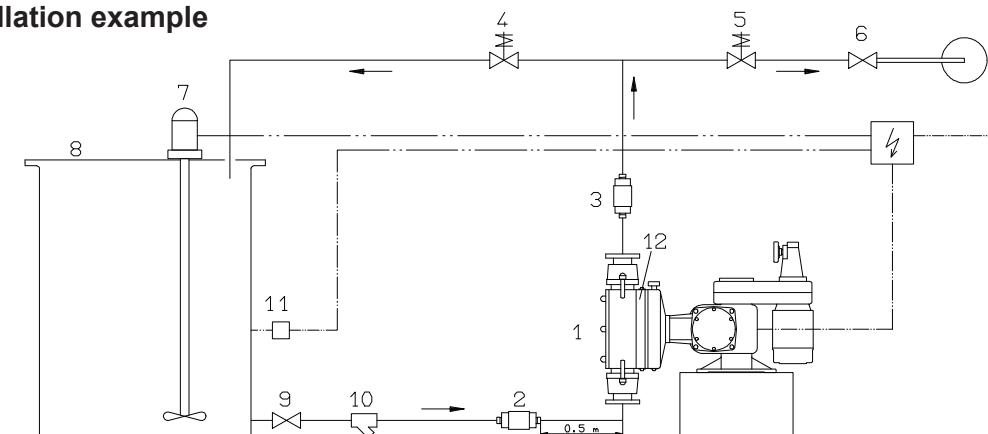
**Installation example**

**Legend**

1. Metering pump GMR	MB 1 06 01	8. PE tank	MB 1 20 01
2. Pulsation dampener f. suction pipe	MB 1 27 01	9. Ball valve	
3. Pulsation dampener f. discharge pipe	MB 1 27 01	10. Dirt trap (filter)	MB 1 22 02
4. Relief valve	MB 1 25 01	11. Dry run protection	MB 4 10 00
5. Backpressure valve	MB 1 25 01	12. Diaphragm failure monitoring	Part No. 41028906
6. Injection nozzle	MB 1 23 01	Use shown fittings when required.	
7. Agitator	MB 1 36 01		

**Dimensions**

GMR			2000	3000	4000
Metering head made of:	Plastic	A	418	478	478
		D	510	523	523
		E	783	795	795
		F	358	388	388
		G	608	620	620
		H	608	620	620
		K	580	610	610
	Stainless steel	A	498	558	558
		D	500	512	512
		E	733	757	757
		F	358	388	388
		G	570	582	582
		H	570	582	582
		K	580	610	610

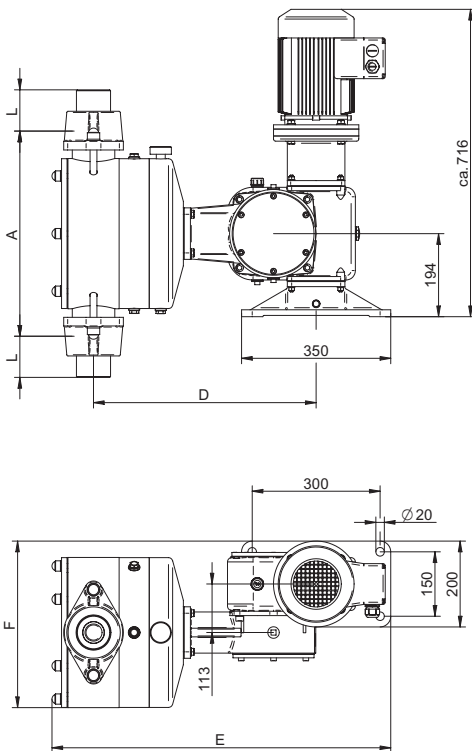
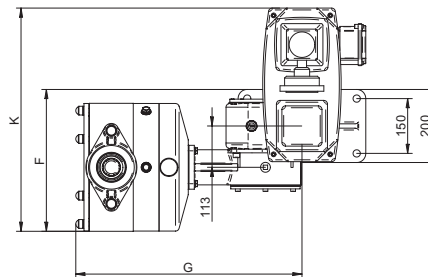
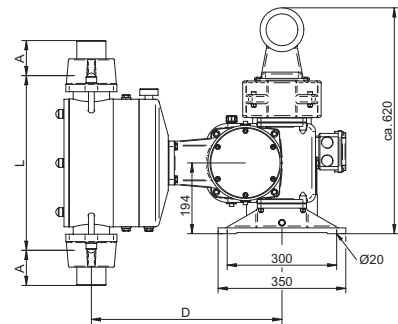
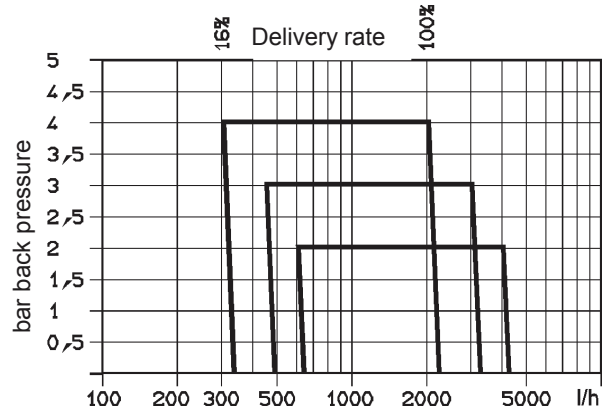
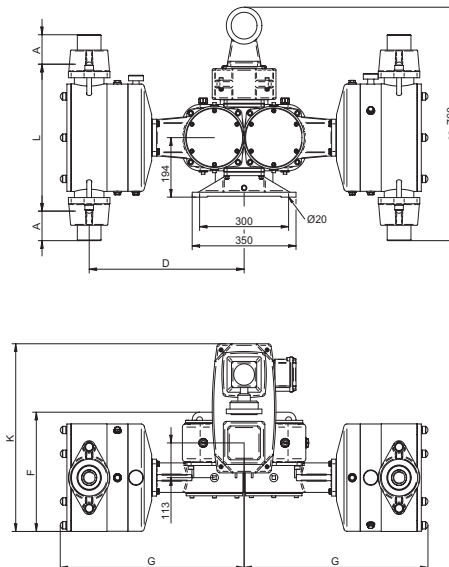
For dimension L see table 5, Connections.

**Dimension drawings  
Simplex pumps**

**Delivery rate characteristics (in control mode)**

**Dimension drawing  
Duplex pump**

**Selection tables**

In order to offer a great variety of metering pumps to the user, the metering pumps have been divided into the most important functional groups. The pump can be individually assembled. The pump must be equipped with the following units:

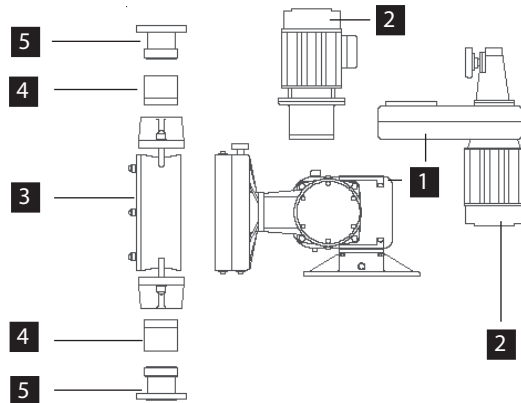
- 1** Gearbox      **2** Motor      **3** Metering Head
- 4** Valves      **5** Connections

The numbers at the metering pump drawing refer to the corresponding selection tables.



<b>1</b> Gearbox						
	Simplex Pump GMR			Duplex Pump ZGMR		
Drive with	2000	3000	4000	2000	3000	4000
				2000	3000	4000
Three phase motor	39439	39423	39425	39470	39471	39472
Gearbox	39438	39422	39424	39473	39474	39475

<b>2</b> Electrical Drives										
Motor type	Power	Size	Design	Speed	Voltage	Fre- quency	Current	IP	ISO- class	Part No.
	[kW]			[1/min]	[V]	[Hz]	[A]			
Three phase motor	2,2	90L	V1	2850	400	50	4,9	55	F	78897
Three phase motor with gearbox (560 - 3640 min <sup>-1</sup> )	2,2	100L	Sonder	1410	400	50	5,2	55	F	32214

**Dimension drawing**

Motor size 90L

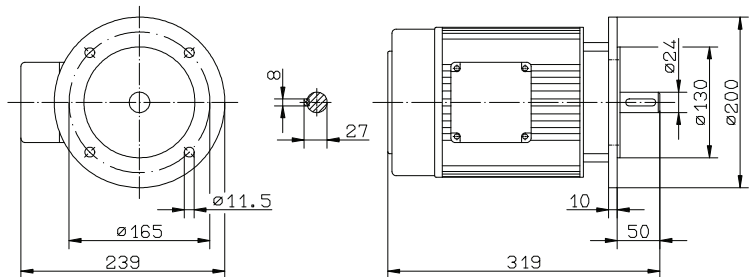

Motor size 100L

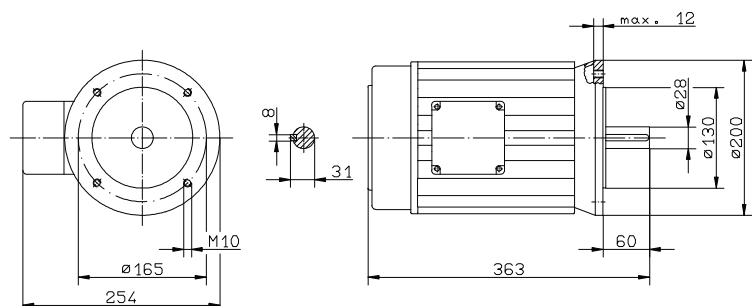

<b>3 Metering heads</b>		
Pump size	PP	1.4571
GMR 2000	32138	32157
GMR 3000	32188	32204
GMR 4000	32188	32204

<b>4 Valves</b>			
PP housing		1.4571 housing	
Valve-spring retainer of PVDF		Valve-spring retainer of 1.4571	
Hastelloy spring			
Sealing material			
Hypalon	Viton	Hypalon	Viton
24072	24073	24071	29961

<b>5 Connections</b>					
GMR	DN	Fig.	d	PVC	1.4571
2000 (3000)*	40	C1	50	21548	-
		D1	G 11/2	32159	25255
		F1	-	27100	27101
2000, 3000 and 4000	50	C1	63	21529	-
		D1	G 2	29888	27046
		F1	-	27103	27104

\* Pressure loss calculation required!

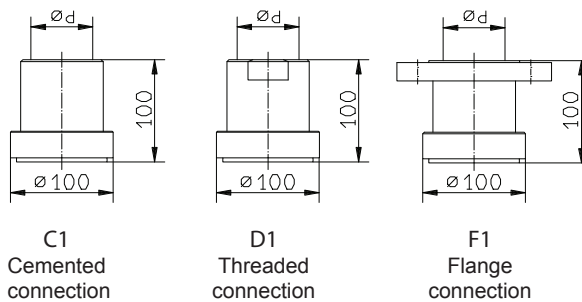

### Ordering example

A metering pump is required for metering lime slurry.

#### Given operating data:

Lime slurry : 3800l/h  
 Back pressure : 3 bar  
 Temperature : 20 °C  
 Mains voltage : 400/230V, 50Hz  
 Manual power adjustment.

#### Selection of the metering pump:

The chemical permits the use of the standard material PP and Hypalon seals.

The plastic flange connection DN 50 is selected for both, the suction and the discharge side.

The 4000 l unit is able to operate at a max. pressure of 2 bar. When having a pressure of 3 bar, the duplex pump ZGMR 2000/2000 is selected.

The metering pump consists of:

	Table	Part No.
Gearbox	<b>1</b>	32347
Motor	<b>2</b>	32214
Metering head	<b>3</b>	32138
Suction valve	<b>4</b>	24072
Discharge valve	<b>4</b>	24072
Connections	<b>5</b>	27103